

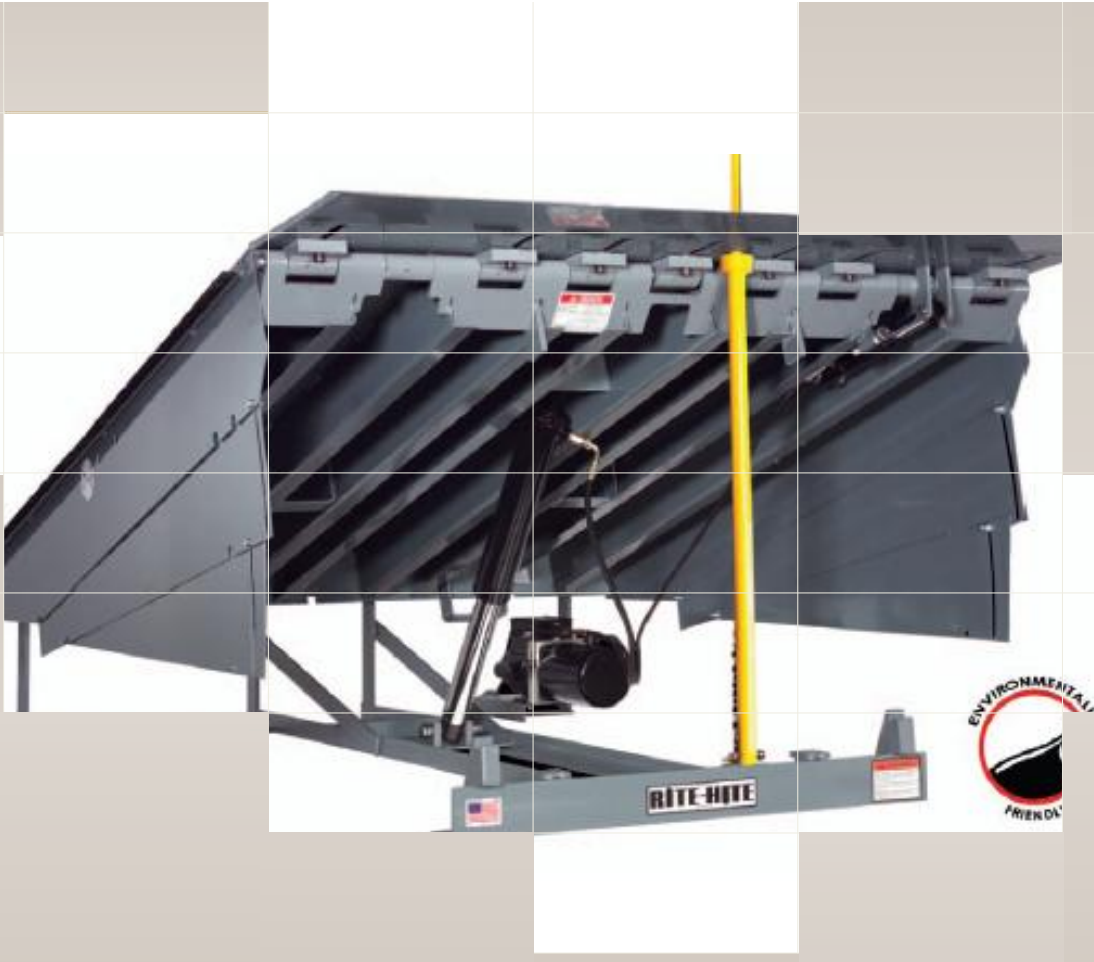

SPECIALIST ACCESS WAY SOLUTIONS



# RITE HITE - DOCK LEVELERS

DESIGNED FOR TODAY'S DOCK ENVIRONMENT

# DOCK LEVELERS

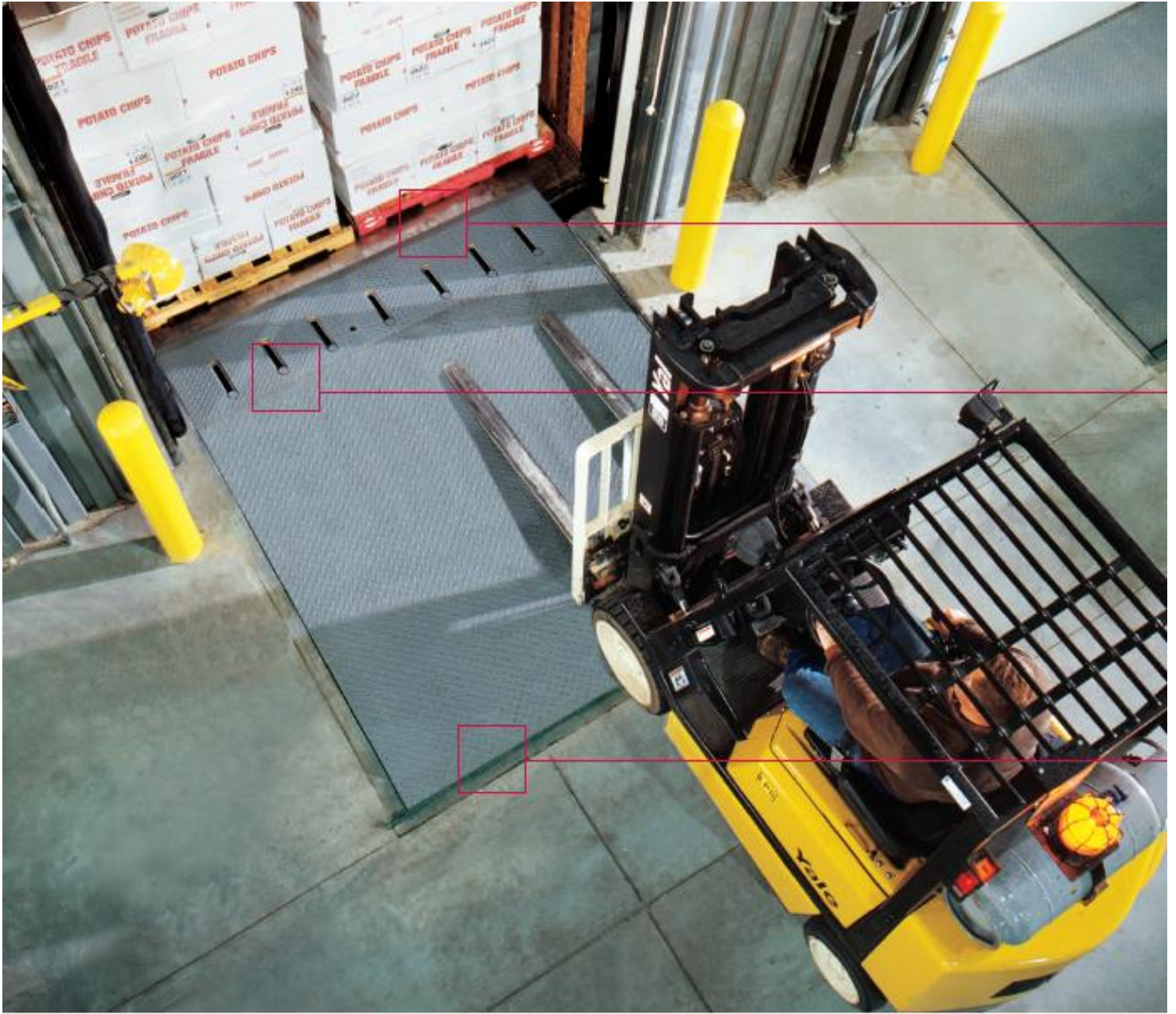

A smoother approach.

# DOCK LEVELERS



An extended lip chamfer (optional) provides a smooth transition from the trailer bed onto the leveler.



Two-point crown control on the front lip hinge distributes the load evenly, smoothes out the transition between the leveler and the trailer bed, and extends the hinge life.



The constant-radius rear hinge creates a smooth transition between the leveler and the warehouse floor.



Overall, about 24% of U.S. workplace illness and injuries are back related,<sup>3</sup> costing an estimated \$80 billion annually.<sup>4</sup> Workers' compensation claims for neck and lower back injuries average \$14,790 and \$11,320 each respectively.<sup>5</sup>

Rite-Hite is continually developing innovative solutions to improve loading dock safety and productivity. In addition to helping prevent loading dock accidents, Rite-Hite's product solutions help eliminate the serious condition known as Dock Shock from your facility.

**Dock Shock** is the constant jolting and jarring caused by a forklift crossing over the bumps and gaps of a traditional dock leveler, resulting in exposure to whole-body vibration. This can lead to back or neck problems which 21% of forklift drivers suffer from.<sup>1</sup>

A first-time back injury can cost your company as much as \$10,000, with chronic back injuries adding up to \$300,000 over time.<sup>2</sup>

But Rite-Hite's extensive engineering process has made innovations like smooth transition possible. Only Rite-Hite offers you a solution to reduce this negative impact to employee health and company profits.

Rite-Hite levelers' flexible, yet durable construction provides the smoothest ride possible between your facility floor and trailer. You'll see fewer employee injuries, less product spills and damage, lower maintenance costs and higher productivity.

<sup>1</sup>Body Vibration and Back Disorders Among Motor Vehicle Drivers and Heavy Equipment Operators, University of British Columbia, April 1999

<sup>2</sup>The Ohio State University

<sup>3</sup>National Safety Council, Injury Facts 2004 Edition

<sup>4</sup>The Economics of Spinal Disorders, JW Frymoyer, 1991

<sup>5</sup>National Safety Council Accident Facts 1997 Edition

# DOCK LEVELERS

## Leading the industry.

Improving industrial safety and productivity through quality and innovation.

### Continued Evolution

Continuing a long history of innovation, Rite-Hite's dock designs progressively address customers' needs.



### Innovative Technology

Using rigorous in-house testing, gathering customer feedback, and examining the latest changes in the trucking, logistics, and material handling industry, Rite-Hite's dock levelers are engineered to offer the smoothest transition in the industry.

### Consistent Quality

Rite-Hite dock levelers are designed to handle your demanding dock needs, offering exceptional durability, reliability and the lowest lifetime ownership costs. Rite-Hite dock levelers are backed by up to a 20-year warranty, based on the customer application.

# DOCK LEVELERS

A choice of three types of Rite-Hite Dock Levelers gives you maximum flexibility in selecting a leveler for your specific loading dock application.

## Rite-Hite Dock Leveler Features

	Hydraulic Levelers	Air-Powered Levelers	Mechanical Levelers
Activation	<p><b>Fully Automatic Operation</b> Push and hold "raise" button on control panel to lift leveler. Lip extends either when "lip-out" button is pushed or when leveler reaches highest level. Provides maximum productivity.</p>	<p><b>Part Automatic/Part Mechanical Operation</b> Push and hold control button to lift leveler. Lip extends after leveler reaches its highest level.</p>	<p><b>Mechanical Operation</b> Pull chain (located at rear of leveler) to release hold-down. Operator then walks leveler down to position on trailer floor. Second pull chain to retract support legs for all below-dock service. Operator must stand on leveler.</p>
Free-Float/ Free-Fall Safety	<p><b>Hydraulic Velocity Fuse</b> Unrestricted float throughout full-service range. No potential for stump-out. Limits platform free-fall to 3" or less from any leveler position.</p>	<p><b>Rite-Hite Stump-Out Solution</b> Allows free-float. Must be retracted for any below-dock service. All free-fall protection is lost if legs are fixed or automatically retract when lip extends.</p>	<p><b>Mechanical Support Legs</b> If not retracted, mechanical support legs can interfere with float during normal loading and unloading. Also known as "stump-out." Legs must be retracted for any below-dock service.</p>
Vacant Dock Drop-Off Protection	<p><b>Yes</b> Automatic SAFE-TIP® barrier available.</p>		<p><b>Not Available</b></p>
Lip Extension	<p><b>Hydraulic</b></p>	<p><b>Mechanical</b></p>	
Automatic Recycle	<p><b>Automatic Return To Dock Level</b> Standard or optional on all models. No selector switch or manual operation required. Leveler automatically restores to safe cross-traffic position.</p>		<p><b>Not Available</b></p>
Maintenance Requirements	<p><b>Low</b></p>	<p><b>Variable</b> Low scheduled maintenance requirements. Mechanical components may require additional maintenance.</p>	
Environmentally Friendly	<p><b>Yes</b> Biodegradable hydraulic fluid.</p>	<p><b>Yes</b></p>	

# DOCK LEVELERS

## RHH Series Hydraulic Levelers

Great performance and easy to use, Rite-Hite Hydraulic Dock Levelers require minimal maintenance and have the lowest lifetime ownership costs.



- ▶ Push-button activation
- ▶ Fully hydraulic platform positioning and lip extension
- ▶ Free leveler movement through full working range
- ▶ Heavy-duty toe guards
- ▶ Advanced hydraulic system for full-range leveler float and automatic free-fall protection
- ▶ Exclusive SAFE-TLIP barrier protects against vacant dock drop-off (optional)
- ▶ Automatic recycle returns leveler to safe dock level position
- ▶ Biodegradable fluid outperforms traditional industrial-grade fluid and is environmentally friendly
- ▶ Hydraulic velocity fuse safety stop system halts rapid leveler descent within 3"

### Hydra-Rite™ Hydraulic Package (optional)

- ▶ 2-1/2" lip cylinder
- ▶ Low-pressure hydraulic system
- ▶ 4" main lifting cylinder
- ▶ Cylinder return lines
- ▶ 1-HP motor
- ▶ Up to a 20-year warranty on hydraulic components



# DOCK LEVELERS

## RHA Series Air-Powered Levelers

Activated by the push of a button, Rite-Hite Air-Powered Dock Levelers feature an advanced low-pressure lifting system and mechanical lip extension.



Rite-Hite Air-Powered Levelers are designed to prevent potential stump-out problems with no legs or rollers required to sense a free-fall situation.

- ▶ Easy, one-button operation
- ▶ Rite-Hite Stump-Out Solution (S.O.S.) provides automatic free-fall protection to stop rapid leveler descent within 3"
- ▶ Low maintenance requirements
- ▶ Exclusive SAFE-TUP barrier protects against vacant dock drop-off (optional)
- ▶ Automatic recycle returns leveler to safe dock level position
- ▶ Air tower easily moved for clean-out or wash down



## Solutions for a safer dock.

Loading dock accidents can cost your company over \$1 million after insurance, with only 20 percent from direct medical expenses and compensation. More significant are the remaining "hidden" costs, including lost productivity and property damage.

A dock leveler from Rite-Hite addresses all your critical safety needs, providing solutions through unique, industry-leading features.



SAFE-TUP barriers improve dock safety after the leveler is stored by protecting people and cargo when trailers aren't present.

# DOCK LEVELERS

## RHM Series Mechanical Levelers

Rite-Hite Mechanical Dock Levelers provide an economical, reliable solution for basic dock leveler applications.



A nine-tooth pawl and ratchet bar provides more surface engagement on the rugged ramp control system, which ensures the industry's most reliable hold-down and reduces leveler popup.

- ▶ Simple operation with smooth, consistent walk-down
- ▶ Superior design of heavy-duty ramp control system features the most proven hold-down device in the industry
- ▶ Safe, positive lip extension provides consistent operation
- ▶ Dual safety stops are provided to stop the leveler platform should the lip become unsupported



The unique through-the-lip design of the SAFE-T-STRUT™ Support System protects personnel during clean out and inspection and provides lockout capability.



Our hydraulic and air-powered levelers automatically return to dock level after use, allowing traffic to safely cross them.

Dangerous dock conditions cause more than 10 percent of all reported forklift accidents each year.

– Source: Powered industrial truck accidents reported through OSHA's "First Report of Serious Accidents" 1985-1990, Modern Materials Handling, February 1996

"Each year, about 100 workers are killed and almost 95,000 are injured in industrial truck accidents."

– OSHA Chief Charles N. Jeffress, Modern Materials Handling, February 1999



# DOCK LEVELERS

## Additional Rite-Hite Levelers & Equipment



### Jumbo™ Hydraulic Leveler

- ▶ Wider platform increases productivity – unique design eliminates pit wall and bumper obstructions for efficient below-dock service
- ▶ Full-width trailer access – 8'6" wide platform deck serves wider trucks with lower beds and full-width loads
- ▶ Simple design – single platform and lifting cylinder provide reliability and safety
- ▶ Integral floating steel bumpers are mechanically operated to minimize maintenance and interference with loading/unloading



### RHV Vertical Storing Hydraulic Leveler

- ▶ Smooth transition between loading dock and trailer reduces jolts to forklift operators and minimizes product and equipment damage
- ▶ Overhead door closes all the way to the pit floor, providing better environmental control over temperature and humidity extremes
- ▶ Prevents dust, insects and rodents from entering, and the tight seal provides additional security by minimizing points of entry when the dock is not being used
- ▶ Vertical storing position allows for easy routine pit cleaning or full wash-down
- ▶ Maintenance/safety support system ensures safe access to the pit
- ▶ Constant-pressure push-button controls keep your operator in control of the platform at all times – no pull chains or mechanical locks



### Dok-Commander® Combination Control Panel

- ▶ Interconnects and integrates control of dock leveler, Dok-Lok® vehicle restraint and other loading dock equipment
- ▶ Simplifies and streamlines dock operation – eliminates multiple control boxes and power lines
- ▶ Operates devices in proper sequence to improve safety, security and environmental control and maximize productivity



**Including: Egmont Doors & totalDOORS**



**Group Including: Egmont Doors & totalDOORS**

0800 807 753 +64 9 407 9619 [www.ultigroup.co.nz](http://www.ultigroup.co.nz) [sales@ultigroup.co.nz](mailto:sales@ultigroup.co.nz)

Northland, Auckland, Waikato, Bay of Plenty, Taranaki, Manawatu, Wellington, Marlborough, Nelson, Christchurch